



Artist-Blacksmith's Association of North America, Inc.
15754 Widewater Drive, Dumfries, VA 22025-1212
Phone: 703-680-1632 Fax: 703-680-6222
abana@abana.org • www.abana.org

PREFACE

The pipe forge plans presented here represent the best thinking as of 1992. Since then best practice in design of this style of forge has evolved somewhat.

First, this is not an inherently safe system. Constant responsible supervision is required. Do not leave this unattended with the gas on for any reason. There are several more current sources for designs including Ron Reil's pages hosted by ABANA. Ron provides some of the thought process that he follows here: <http://ronreil.abana.org/design1.shtml>. Notable is the recommendation for at least 2 inches of insulation and some sort of alumina or zirconia (e.g. ITC-100) based interior coating.

As shown the ends of this forge are open; that is not as efficient a design as keeping the ends at least partially closed. A stack of insulating fire bricks (or hard fire bricks) solves this and retains flexibility. Just be sure to leave enough of an opening for the exhaust to escape. A general rule of thumb is to leave 7 times the area of the air inlet open for exhaust.

Ron prefers venturi type gas pressure aspirated burners. This is a blower operated burner which is also popular. With such a design, the minimum safety provision would be a normally closed solenoid valve on the gas line plus a line powered start-stop relay to make sure a power interruption causes the gas to shut off and stay off. The solenoid valve without the relay is worse than doing nothing.

Implement any such design at your own risk.

Paul Boulay, 2008.

Pipe Gas Forge Plans - - Designed and Donated by Hans Peot ©1992

Construction and Installation

Forge

The forge is made from 10" ID pipe with a hole cut out close to the top and midway down the side so that when the burner is installed the flame will be tangent to and just touch the top of the ceramic fiber insulation. A piece of 2 1/2" pipe is welded at this position with a 3/8" NC nut welded to the top to accept a set screw to hold the burner in place.

Insulation

The ceramic fiber is then installed and a long knife or hacksaw blade is used to cut a hole where the burner is to be installed. The ceramic fiber must be 1" thick, 8 pound density; and can be "DuraBlanket" or equivalent other brand. A 4 1/2" X 8" X 1" high temperature firebrick is placed in the bottom to protect the ceramic fiber during use.

Burner Assembly

The burner assembly is made from 2" pipe fittings with an air gate valve to control airflow. The blower is a 120-150 CFM blower. The nozzle is a brass plug with a 1/16" hole drilled into it.

Installation

Set the forge on a non-combustible surface. Install the burner assembly with the fan in the vertical down position so that the flame from the forge cannot enter the blower. Wrap duct tape around the pipe where the burner assembly enters the forge. If the forge has no back, block off the back with firebricks. On the front of the forge, arrange the firebricks so you have an opening for your work that is about 3" wide. Connect the pressure regulator (0 - 20 PSI) to the propane tank and the hose to the burner assembly.

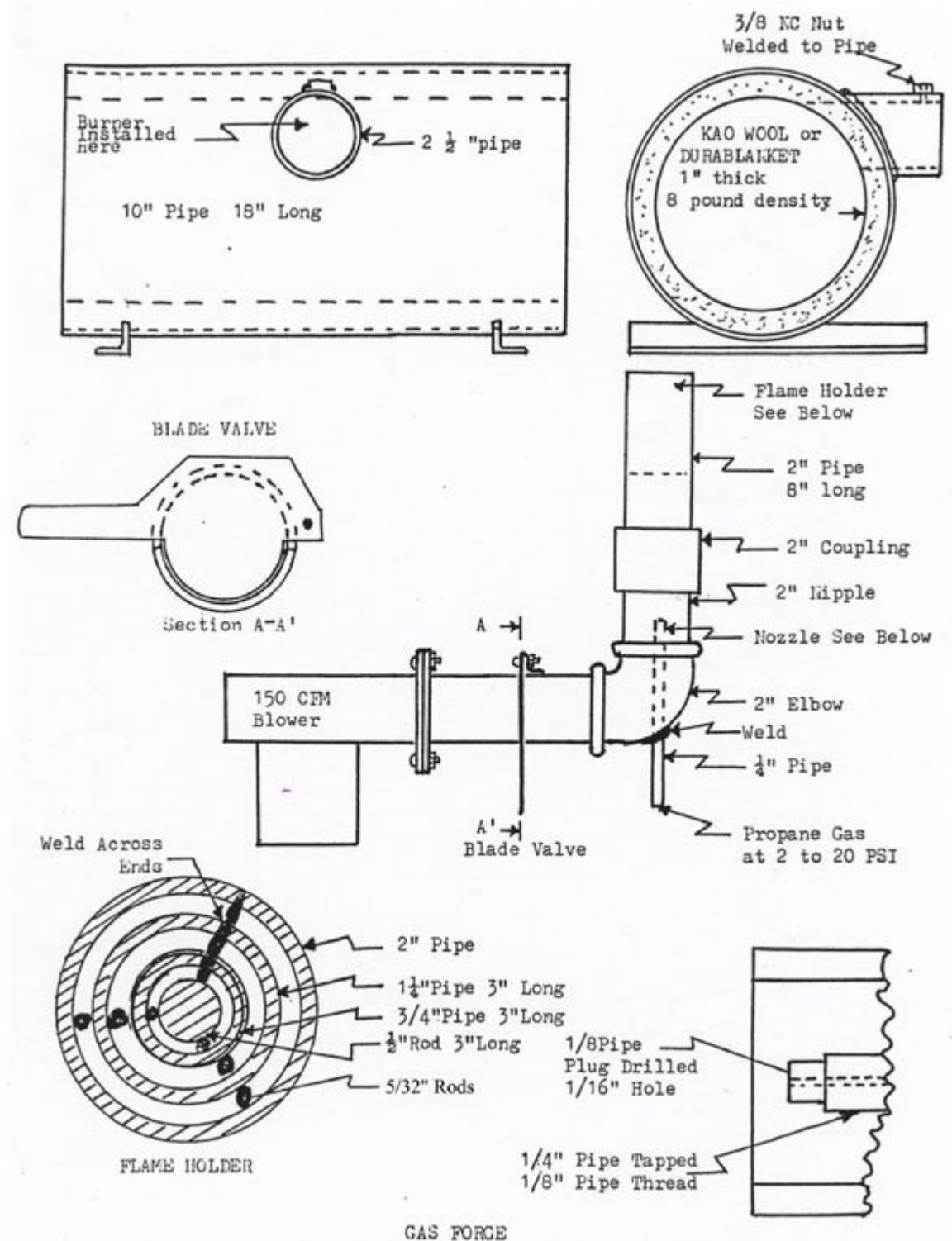

Operating Instructions

Open the air control valve about 1/3 of the way. Turn the regulator valve all the way off and turn the blower on. Using a propane torch, stand to one side of the forge and hold the flame next to the front opening. Turn on the gas to the burner assembly. Slowly open the pressure regulator until the forge lights. Adjust gas pressure and airflow until the interior of the forge is at its brightest.

To stop the forge, simply turn off the two gas valves and the blower.

Warnings

Carcinogens

DuraBlanket, KAO Wool, and other ceramic fiber insulations give off fine dust when cut and during installation. The dust has been shown to cause cancer in animals at high concentrations. On the basis of these tests, OSHA has designated the material a carcinogen for humans. There have been no reported cases of cancer in humans who have been exposed to the dust from this material even though the material has been in use since the mid-fifties. Therefore, to avoid risk when installing or cutting this material, do not use power equipment; use a knife and spray the material with a plant mister to dampen it. Wear a 3M 9970 or equivalent disposable dust respirator during all work. Once the ceramic fiber is installed, avoid disturbing it during use by placing a one-inch brick on the bottom of the forge and avoid stabbing the ceramic fiber on the sides. There is no hazard once the ceramic fiber is installed. A controlled test was conducted on one of these forges with the forge in continuous operation and use. The test took place over an 8 hour time period with appropriate sensors. The measured particulate was 100 times below the standard established by the industry. Once the ceramic fiber insulation has been exposed to high heat for a period of time, some of the surface is converted to cristobalite, a type of crystalline silica which is also designated as a carcinogen. Therefore, when it becomes necessary to remove the ceramic fiber insulation, wet the ceramic fiber thoroughly with water. The particulate measurement above also included cristobalite particles.

Carbon Monoxide

When the forge is operating at best heat, carbon monoxide is being given off. Therefore, operate this forge in a well-ventilated area to prevent the buildup of noxious gases.

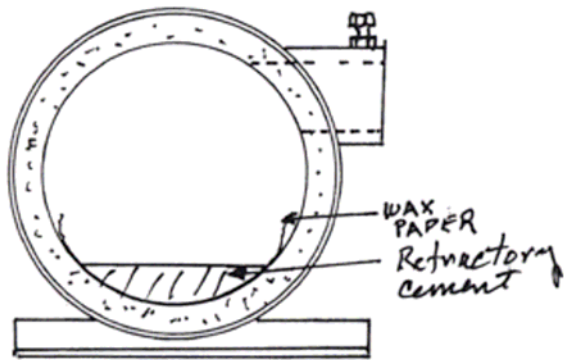

Figure 1

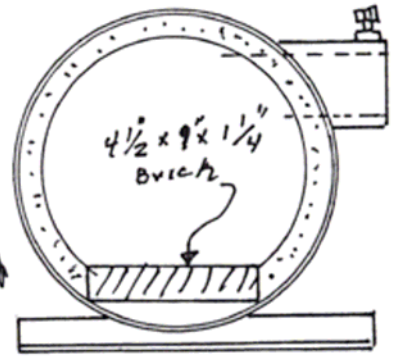

Figure 2

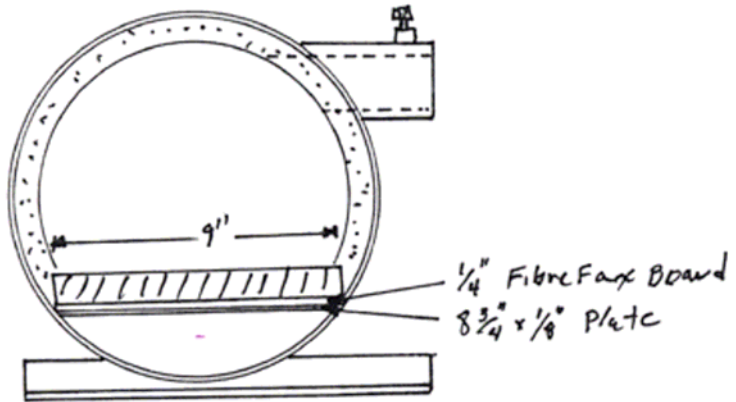

Figure 3

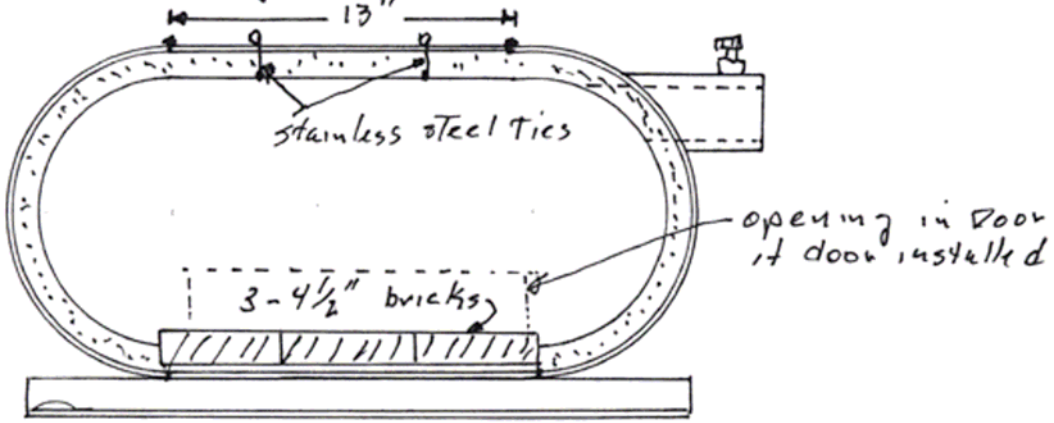

Figure 4

Alternative Configurations

Figure 1

This is a forge that has a layer of high temperature refractory cement in the bottom. To accomplish this, a layer of wax paper is placed over the ceramic insulation material and then the wet refractory cement is applied on top of the wax paper. The thickness of the refractory should be about 1". Let the refractory dry completely before firing the forge. This configuration works well for many knife makers, as the refractory is more impervious to borax flux, which tends to dissolve the hard bricks and ceramic insulation.

Figure 2

This shows a 4 1/2" X 9" x 1 1/4" high temperature brick installed directly on the bottom of the pipe with the ceramic fiber running to the edge of the brick. The brick makes an excellent working surface.

Figure 3

This forge is made out of 12" ID pipe. A piece of 1/8" plate 8 3/4" wide is welded to the bottom of the pipe. A layer of 1/4" ceramic fiberboard is placed on top of the plate to reduce heat loss through the bricks. 9" half bricks are then set on top of the fiberboard.

Figure 4

This forge is wider to accommodate larger work. The 10" pipe may be cut in half and different length plates can be welded to the edges to provide extra width. Increasing the width in multiples of 4 1/2" precludes the necessity of cutting bricks. In the forge shown, 13" plates were used, allowing three 4 1/2" bricks to be placed in the bottom. A 1/4" ceramic fiberboard 13 1/4" wide is placed under the bricks to minimize heat loss. With a forge this wide, it may become difficult to place bricks in front of the forge. To solve this, a plate can be hinged at the top of the forge and lined with ceramic fiber on the inside. The plate should have an opening that is approximately 3" X 10" and located in the bottom center of the plate. The same burner should provide sufficient heat with a higher gas pressure and greater airflow.

All Forges

Instead of firebricks, a plate can be welded to the back and lined with ceramic fiber. A small door can be cut in the back so as to accommodate longer pieces of work. Any thickness pipe can be used for the forge, but it is suggested to use 10 or 14 gauge grain pipe to minimize the weight of the forge.

ALTERNATE BURNER ASSEMBLY

